

Centrifugal pumps

Medium flow

 Clean water

 Agricultural use

 Industrial use

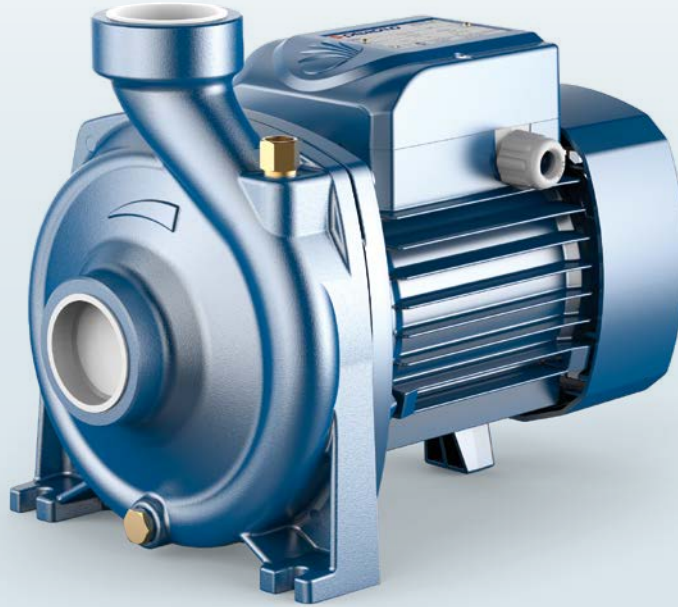

PERFORMANCE RANGE

- Flow rate up to **700 l/min** (42 m³/h)
- Head up to **39 m**

APPLICATION LIMITS

- Manometric suction lift up to **7 m**
- Liquid temperature between **-10 °C** and **+90 °C**
- Ambient temperature up to **+40 °C**
- Max. working pressure:
 - **6 bar** for HF 5-50-51
 - **10 bar** for HF 5M-70
- Continuous service **S1**

CONSTRUCTION AND SAFETY STANDARDS

EN 60335-1
IEC 60335-1
CEI 61-150

EN 60034-1
IEC 60034-1
CEI 2-3



CERTIFICATIONS

Company with management system certified DNV
ISO 9001: QUALITY
ISO 14001: ENVIRONMENT

INSTALLATION AND USE

Suitable for use in civil and agricultural applications. The high efficiency and continuous duty capabilities makes these pumps ideal for use in applications such as flood and spray irrigation, drawing water from lakes, rivers and wells, or for any number of different industrial applications where the characteristics of high flow rates and mid to low head are required. The pump should be installed in an enclosed environment or sheltered from inclement weather.

OPTIONS AVAILABLE ON REQUEST

- Pump body with NPT ANSI B 1.20.1 threaded ports
- Special mechanical seal
- Other voltages
- IP X5 class protection for HF 5M-70

GUARANTEE

2 years subject to terms and conditions

CHARACTERISTIC CURVES AND PERFORMANCE DATA

60 Hz n= 3450 rpm HS= 0 m

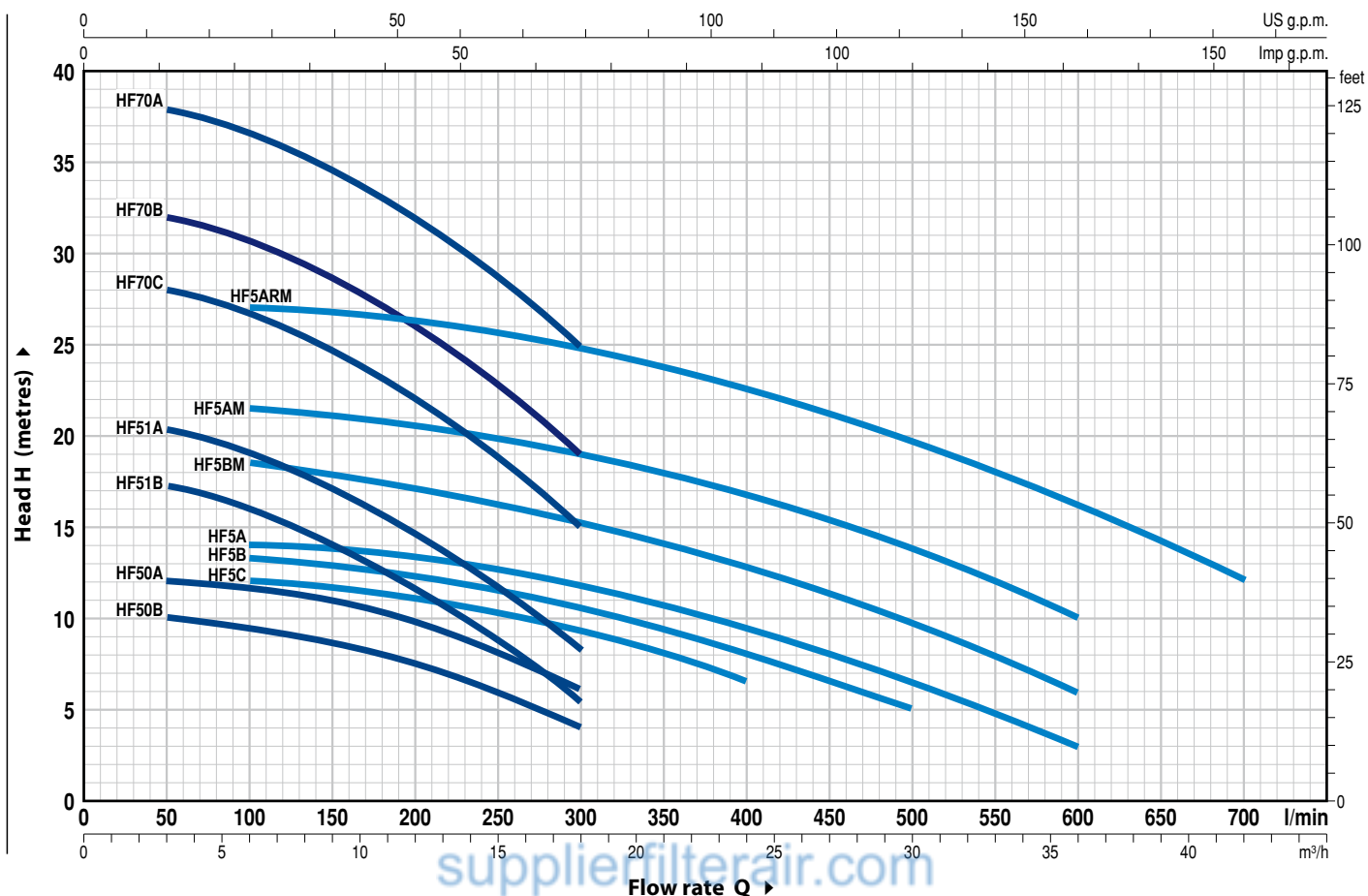

MODEL		POWER (P ₂)		▲	Q	H metres															
Single-phase	Three-phase	kW	HP			0	3	6	9	12	15	18	21	24	30	36	42				
					0	50	100	150	200	250	300	350	400	500	600	700					
HFm 50B	HF 50B	0.37	0.50	IE2	10	10	9.5	8.5	7.5	6	4										
HFm 50A	HF 50A	0.55	0.75		12	12	11.5	11	9.6	8	6										
HFm 51B	HF 51B	0.60	0.85	IE2	18.2	17.2	16	14	11.5	9	5.4										
HFm 51A	HF 51A	0.75	1		21.2	20.2	19	17	14.5	11.6	8.4										
HFm 70C	HF 70C	1.1	1.5	IE2	29	28	26.5	24.5	22	18.5	15										
HFm 70B	HF 70B	1.5	2	IE3	33	32	30.5	28.5	26	22.5	19										
HFm 70A	HF 70A	2.2	3		39	38	36.5	34.5	32	28.5	25										
HFm 5C	HF 5C	0.55	0.75	IE2	12.5	-	12	11.7	11	10.2	9.2	8	6.5								
HFm 5B	HF 5B	0.75	1		13.7	-	13.2	13	12.5	11.6	10.5	9.2	8	5							
HFm 5A	HF 5A	1.1	1.5		14.5	-	13.8	13.5	13.2	12.6	11.8	10.5	9.2	6.5	3						
HFm 5BM	HF 5BM	1.1	1.5	IE2	19	-	18.5	18	17	16	15.2	14	12.8	9.7	6						
HFm 5AM	HF 5AM	1.5	2	IE3	22	-	21.5	21	20.5	19.8	19	18	16.8	13.8	10						
HFm 5ARM	HF 5ARM	2.2	3		27	-	27	26.8	26.4	25.6	24.8	23.8	22.5	19.8	16.2	12					

Q = Flow rate H = Total manometric head HS = Suction height

Tolerance of characteristic curves in compliance with EN ISO 9906 Grade 3B.

▲ Performance class of the three-phase motor (IEC-60034-30)

POS. COMPONENT CONSTRUCTION CHARACTERISTICS

1	PUMP BODY	Cast iron complete with threaded ports in compliance with ISO 228/1					
2	BODY BACKPLATE	Stainless steel AISI 304 (cast iron for HF 5M-70)					
3	IMPELLER	Brass					
4	MOTOR SHAFT	Stainless steel EN 10088-3 - 1.4104					
5	MECHANICAL SEAL	Pump	Seal	Shaft	Materials		
		<i>Model</i>	<i>Model</i>	<i>Diameter</i>	<i>Stationary ring</i>	<i>Rotational ring</i>	<i>Elastomer</i>
		HF 50	AR-12	Ø 12 mm	Ceramic	Graphite	NBR
		HF 5-51	AR-14	Ø 14 mm	Ceramic	Graphite	NBR
		HF 5M-70	FN-18	Ø 18 mm	Graphite	Ceramic	NBR
6	BEARINGS	Pump	Model				
		HF 50	6201 ZZ / 6201 ZZ				
		HF 5-51	6203 ZZ / 6203 ZZ				
		HF 5M-70	6204 ZZ / 6204 ZZ				
7	CAPACITOR	Pump	Capacitance				
		<i>Single-phase</i>	<i>(220 V)</i>	<i>(110 V or 127 V)</i>			
		HFm 50B	10 µF - 450 VL	25 µF - 250 VL			
		HFm 50A	14 µF - 450 VL	25 µF - 250 VL			
		HFm 51B	20 µF - 450 VL	60 µF - 300 VL			
		HFm 51A	20 µF - 450 VL	60 µF - 300 VL			
		HFm 70C	25 µF - 450 VL	60 µF - 250 VL			
		HFm 70B	45 µF - 450 VL	80 µF - 250 VL			
		HFm 70A	50 µF - 450 VL	-			
		HFm 5C	16 µF - 450 VL	60 µF - 300 VL			
		HFm 5B	20 µF - 450 VL	60 µF - 300 VL			
		HFm 5A	25 µF - 450 VL	60 µF - 300 VL			
		HFm 5BM	25 µF - 450 VL	60 µF - 250 VL			
		HFm 5AM	45 µF - 450 VL	80 µF - 250 VL			
	HFm 5ARM	50 µF - 450 VL	-				
8	ELECTRIC MOTOR	<p>HFm: single-phase 220 V - 60 Hz with thermal overload protector incorporated into the winding. HF: three-phase 220/380 V - 60 Hz or 220/440 V - 60 Hz.</p> <p>⇒ The three-phase pumps are fitted with high performance motors up to P₂=1.1kW in class IE2 and from P₂=1.5kW in class IE3 (IEC 60034-30)</p> <ul style="list-style-type: none"> - Insulation: class F - Protection: IP X4 					

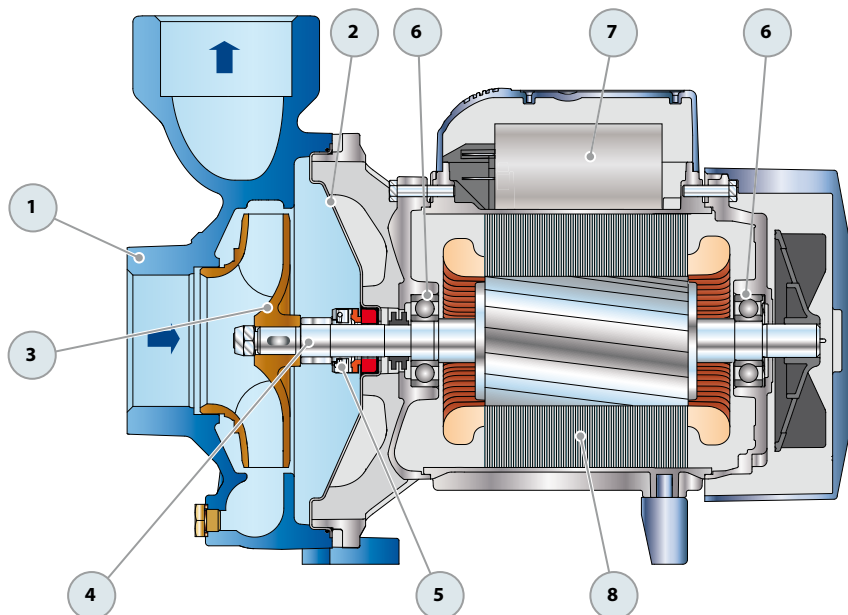

DIMENSIONS AND WEIGHT

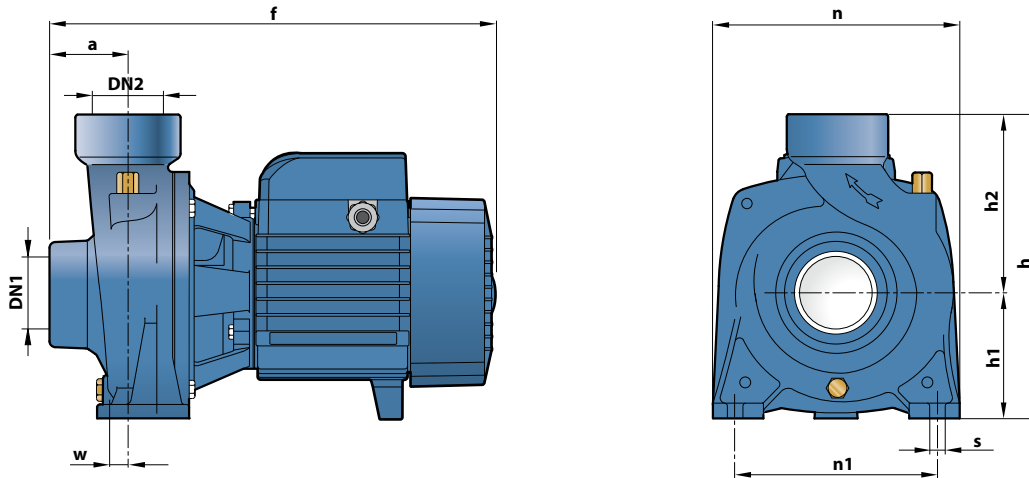

MODEL		PORTS		DIMENSIONS mm									kg		
Single-phase	Three-phase	DN1	DN2	a	f	h	h1	h2	n	n1	w	s	1~	3~	
HFm 50B	HF 50B	1½"	1½"	42	265	200	82	118	166	135	-3	10	8.3	7.8	
HFm 50A	HF 50A			9.2	8.5										
HFm 51B	HF 51B			12.9	11.9										
HFm 51A	HF 51A			45	300	225	92	133	190	160	4	12	12	13.0	12.0
HFm 70C	HF 70C			19.0	18.6										
HFm 70B	HF 70B			21.8	20.5										
HFm 70A	HF 70A			48.5	373	269	114	155	216	171	12	12	12	12	24.4
HFm 5C	HF 5C	2"	2"	59	386	260	110	150	208	160	12.5	11	14.5	13.3	
HFm 5B	HF 5B												14.5	13.3	
HFm 5A	HF 5A												15.3	14.9	
HFm 5BM	HF 5BM												20.1	19.2	
HFm 5AM	HF 5AM												21.5	20.8	
HFm 5ARM	HF 5ARM												22.3	21.5	

ABSORPTION

MODEL	VOLTAGE		
Single-phase	220 V	110 V	127 V
HFm 50B	2.5 A	5.0 A	4.7 A
HFm 50A	3.9 A	7.8 A	7.3 A
HFm 51B	4.6 A	9.2 A	8.5 A
HFm 51A	5.7 A	11.4 A	10.6 A
HFm 70C	8.0 A	16.0 A	14.9 A
HFm 70B	9.0 A	18.0 A	16.5 A
HFm 70A	14.5 A	-	-
HFm 5C	4.2 A	8.4 A	7.8 A
HFm 5B	5.2 A	10.4 A	9.7 A
HFm 5A	6.5 A	13.0 A	12.0 A
HFm 5BM	7.4 A	14.8 A	13.8 A
HFm 5AM	10.2 A	20.5 A	18.0 A
HFm 5ARM	13.0 A	-	-

MODEL	VOLTAGE			
Three-phase	220 V	380 V	220 V	440 V
HF 50B	1.9 A	1.1 A	2.5 A	1.5 A
HF 50A	3.3 A	1.9 A	3.5 A	2.0 A
HF 51B	4.2 A	2.4 A	3.1 A	1.8 A
HF 51A	4.4 A	2.6 A	4.2 A	2.3 A
HF 70C	5.7 A	3.3 A	4.5 A	2.6 A
HF 70B	7.4 A	4.3 A	6.6 A	3.7 A
HF 70A	10.2 A	5.9 A	9.0 A	5.0 A
HF 5C	3.6 A	2.1 A	3.8 A	2.2 A
HF 5B	4.0 A	2.3 A	3.1 A	1.8 A
HF 5A	5.7 A	3.3 A	4.5 A	2.6 A
HF 5BM	5.9 A	3.4 A	4.8 A	2.8 A
HF 5AM	7.4 A	4.3 A	6.4 A	4.0 A
HF 5ARM	10.0 A	5.8 A	9.0 A	5.0 A